

HÖGG
LIFTSYSTEME

GANSER
LIFTSYSTEME

RL60

The unique
stairlift



More mobility – for a better quality of life



RL60

The solution to overcome your staircase with the wheelchair

The wheelchair ceiling lift is a unique solution for the wheelchair user to be completely independent and mobile. The sturdy design is in accordance with the highest safety standard to ensure comfortable transportation between different floors. Boarding, departure and parking areas can be adapted to suit your needs and local conditions. Attaching the wheelchair to the ceiling lift and the operation are simple thanks to ergonomic controls and customization, with a few simple steps. This also with limited motor skills by the lift user or by an attendant.



The hooking on the rear of the wheelchair is done by driving in with the wheelchair, in front by the adaptation of the holder, without effort



1. Attachment to concrete ceiling or wooden ceiling possible
2. Parking lot of the lift
3. Driving into the receiving bracket

Easy construction

The RL60 can be easily installed everywhere – even in narrow staircases with steep incline. By simple adjustments even the rail guide through doors is possible. The drive mechanism employs the latest technology for your guarantee of long-term safety.

Platform optional

The platform is attached directly to the slings. With the wheelchair you drive on the platform and secure yourself with the belt.



Manual control unit on spiral cable for individual operation



Front attachment to the wheelchair



Wireless station for calling and sending the lift



Rail led elegantly under the stairs





Your professional on all stairs



TECHNICAL DETAILS

HÖGG LIFTSYSTEME

Manufacturer:	Högg Liftsysteme AG, Switzerland
Nominal load:	160kg, optional 250 kg
Controls:	key switch hold-on scanner (pressure scanner) emergency stop
Drive system:	37V CA / pinion on chain
Rail:	aluminium rail
Electrical connection:	230V CA Fuse 13A
Speed:	max. 0,15m/sec
Technical conformity:	CE/TÜV approved
Area of application:	inclines from 0 degrees (horizontal) to 60 degrees
Standard design:	including wheelchair attachment bracket
Optional:	– cordless call and transmission points – special mounting – platform – special applications

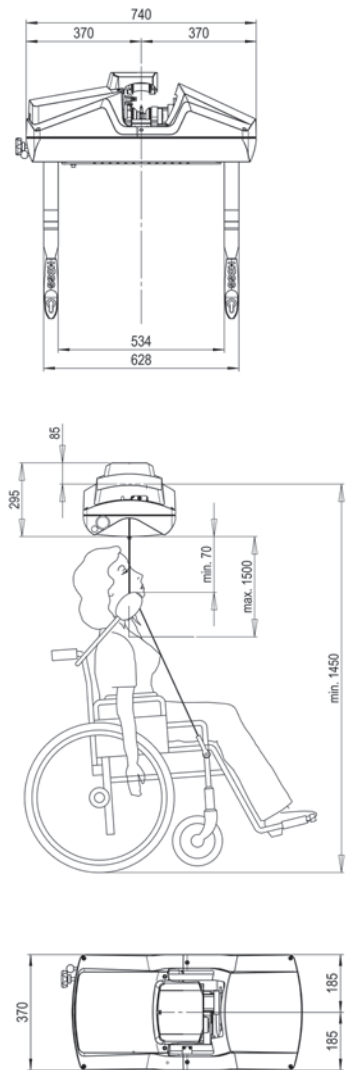

Subject to changes without notice

lifts – wheelchair stairlift – stairlift with seat – lifting platform – elevator

hoegg lift ch

Wilerstrasse 137
CH-9620 Lichtensteig
Tel. 071 987 66 80
info@hoegglift.ch



GANSER LIFTSYSTEME

Markt 26, A-4171 St. Peter am Wimberg
Tel. +43 7282 8071-0
office@ganserlifte.at | www.ganserlifte.at